

Product Description:

The Nxbeam NFE2000-DE is a GaN Front-End Module (FEM) fabricated in 0.2um GaN HEMT on SiC. This part is ideally suited for 5G base station terminals. The FEM operates from 25 to 29 GHz and consists of a transmit power amplifier, low noise receiver amplifier, and a low loss high isolation transmit/receive switch. The NFE2000-DE comes in die form with RF inputs and outputs matched to 50 Ω and with DC blocking capacitors for easy system integration.

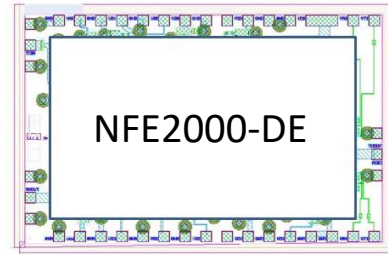

Dimensions: 3.5 x 2.25 x 0.1 (mm)

Electrical Specifications – RX Mode:

Test Conditions: RXVd = 24 V, RXId = 0.08 A, RXSW = 0 V, TXSW = -10 V, TXVd = 0 V,

Parameter	Min	Typical	Max	Unit
Frequency	25		29	GHz
Gain (small signal)		17		dB
Noise Figure		3		dB
Input Return Loss		> 6		dB
Output Return Loss		> 8		dB
Output TOI		TBD		dBm

Electrical Specifications – Tx Mode:

Test Conditions: TxVd = 20 V, TxId = 0.5 A, TxSW = 0 V / RxSW = -10 V, RxVd = 0 V

Parameter	Min	Typical	Max	Unit
Frequency	25		29	GHz
Gain (small signal)		22		dB
Psat		38		dBm
PAE at Psat		19		%
Input Return Loss		> 8		dB
Output Return Loss		> 16		dB
ACPR		TBD		dBc

Recommended Operating Conditions:

Parameter	Typical Value	Typical Range	Unit
TXVd (Transmit Drain Voltage)	24	20 to 28	V
TXIdq (Transmit Drain Current)	440	220 to 880	mA
TXVg (Transmit Gate Voltage)	-4.0	-5 to -3	V
RXVd (Receive Drain Voltage)	20	10 to 24	V
RXIdq (Receive Drain Current)	85	40 to 85	mA
RXVg (Receive Gate Voltage)	-4.0	-5 to -3	V
TXSW (Transmit Mode)	0	-1 to +1	V
TXSW (Receive Mode)	-10	-20 to -10	V
RXSW (Transmit Mode)	-10	-20 to -10	V
RXSW (Receive Mode)	0	-1 to +1	V

Max Operating Condition:

Parameter	Min	Max	Unit
TXVd (Transmit Drain Voltage)		28	V
TXIdq (Transmit Drain Current)		1.3	A
TXVg (Transmit Gate Voltage)	-8	0	mA
RXVd (Receive Drain Voltage)		28	mA
RXIdq (Receive Drain Current)		125	mA
RXVg (Receive Gate Voltage)	-8	0	mA
TXSW	-20	1	V
TXSW	-20	1	V

Receive Path, Small Signal: (all measurements CW in-fixture unless otherwise stated)

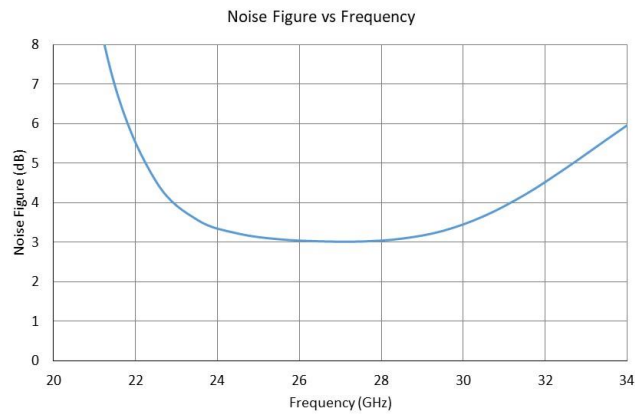
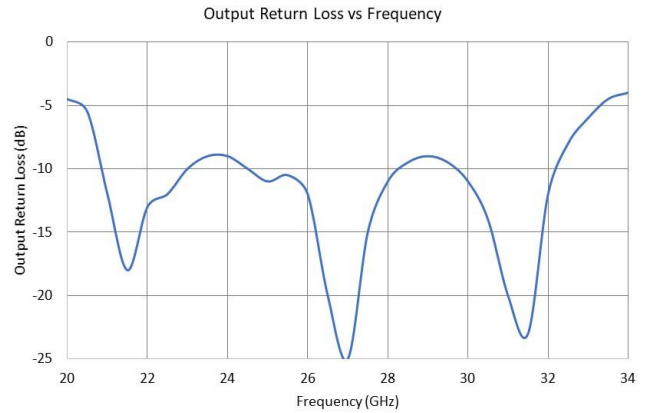
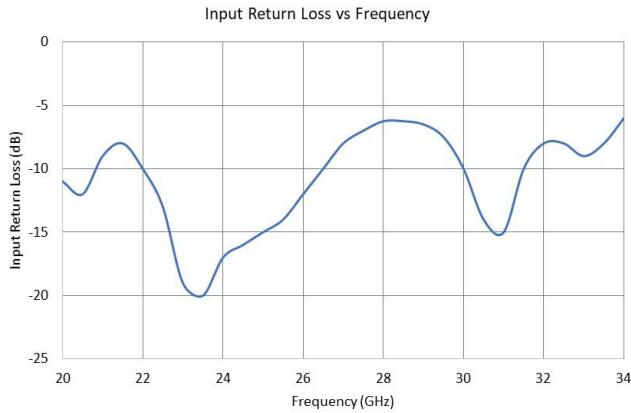
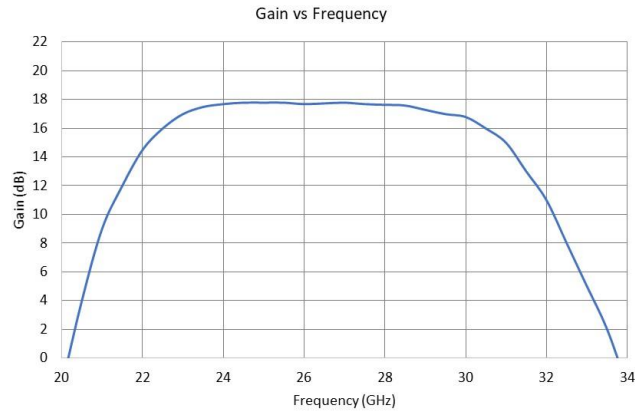

Transmit Path, Small Signal: (all measurements CW in-fixture unless otherwise stated)

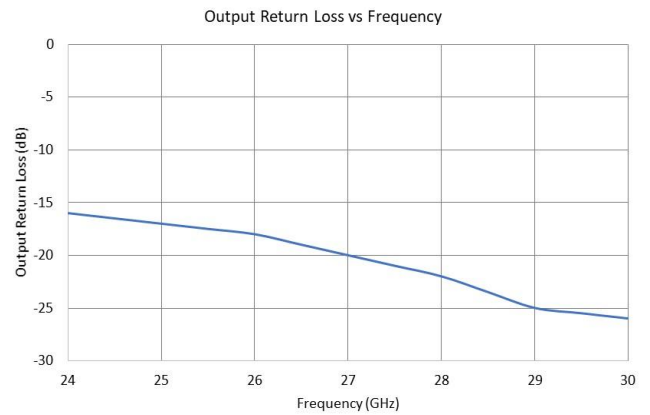
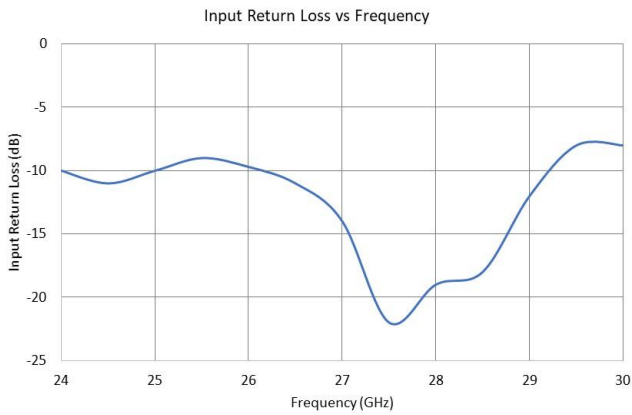
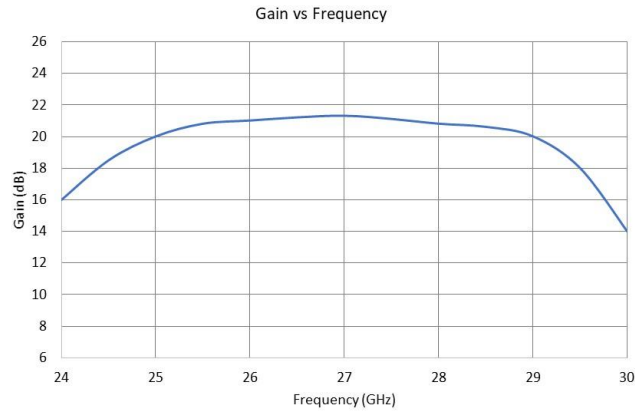

Transmit Path, Large Signal: (all measurements CW in-fixture @25C)

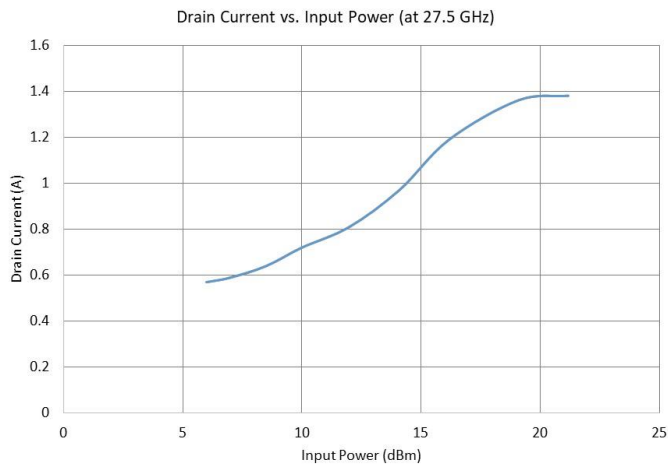
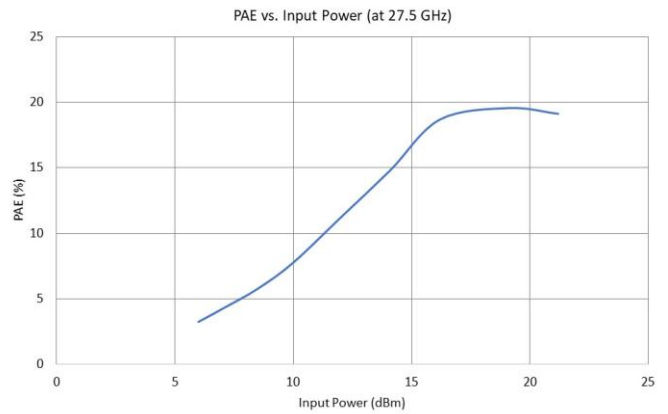
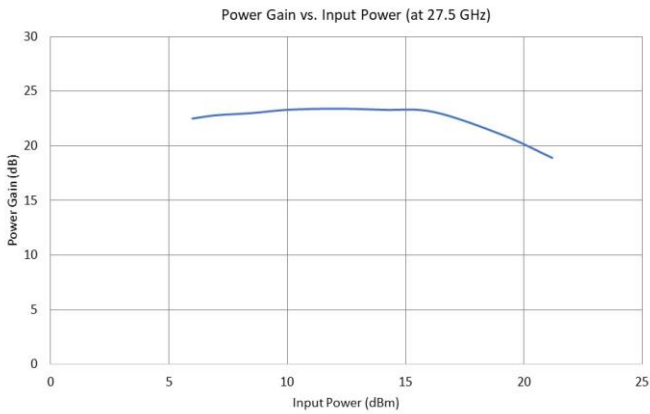
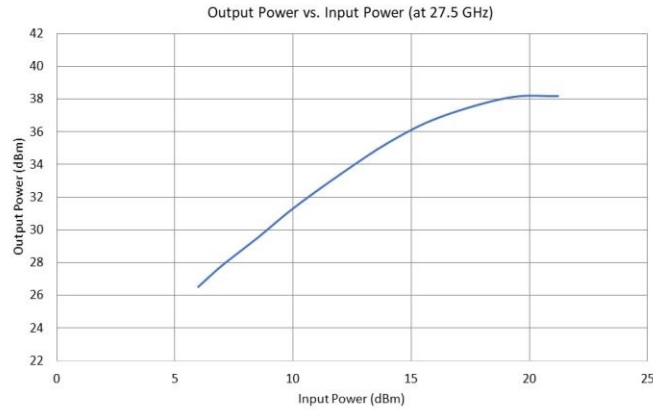

Circuit Block Diagram:

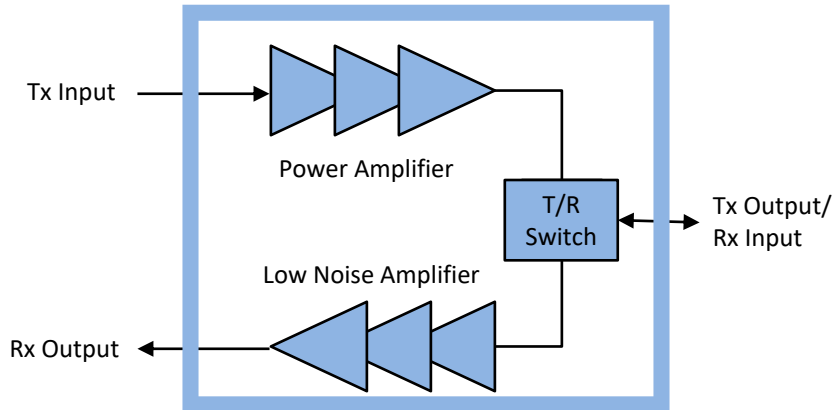

Off-Chip Component Recommendation:

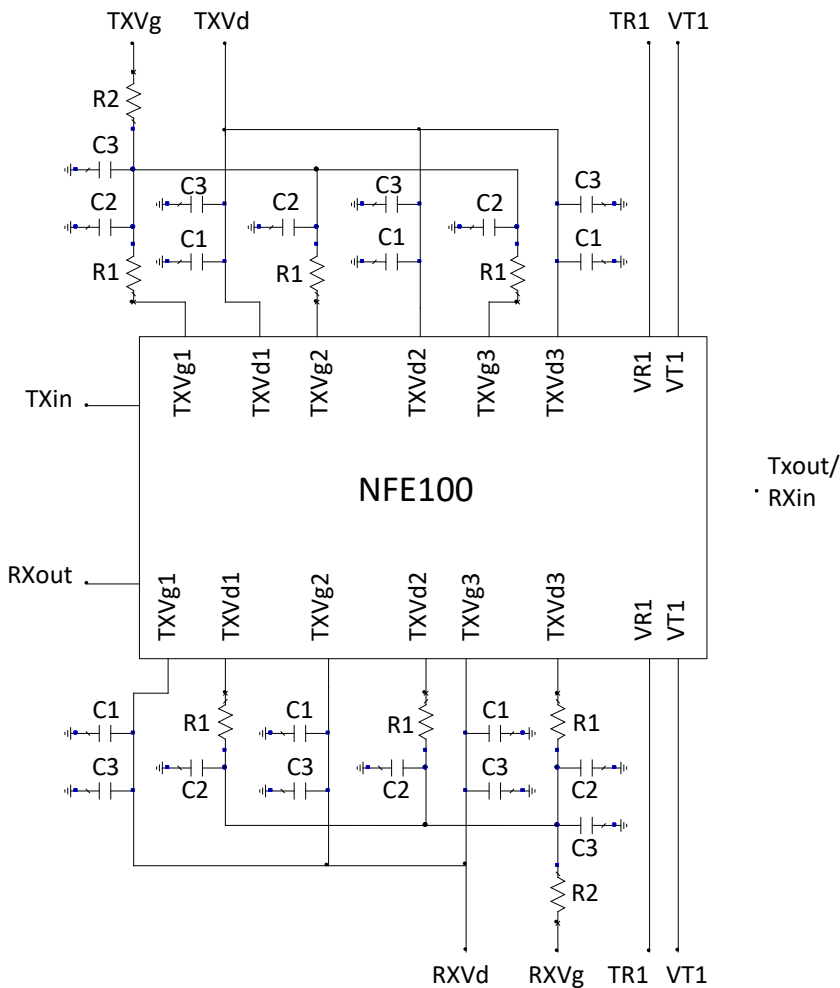

Element	Value	Unit
C1	100	pF
C2	330	pF
C3	10	nF
R1	10	ohm
R2	150	ohm

Chip Layout Information: (all dimensions in mm)

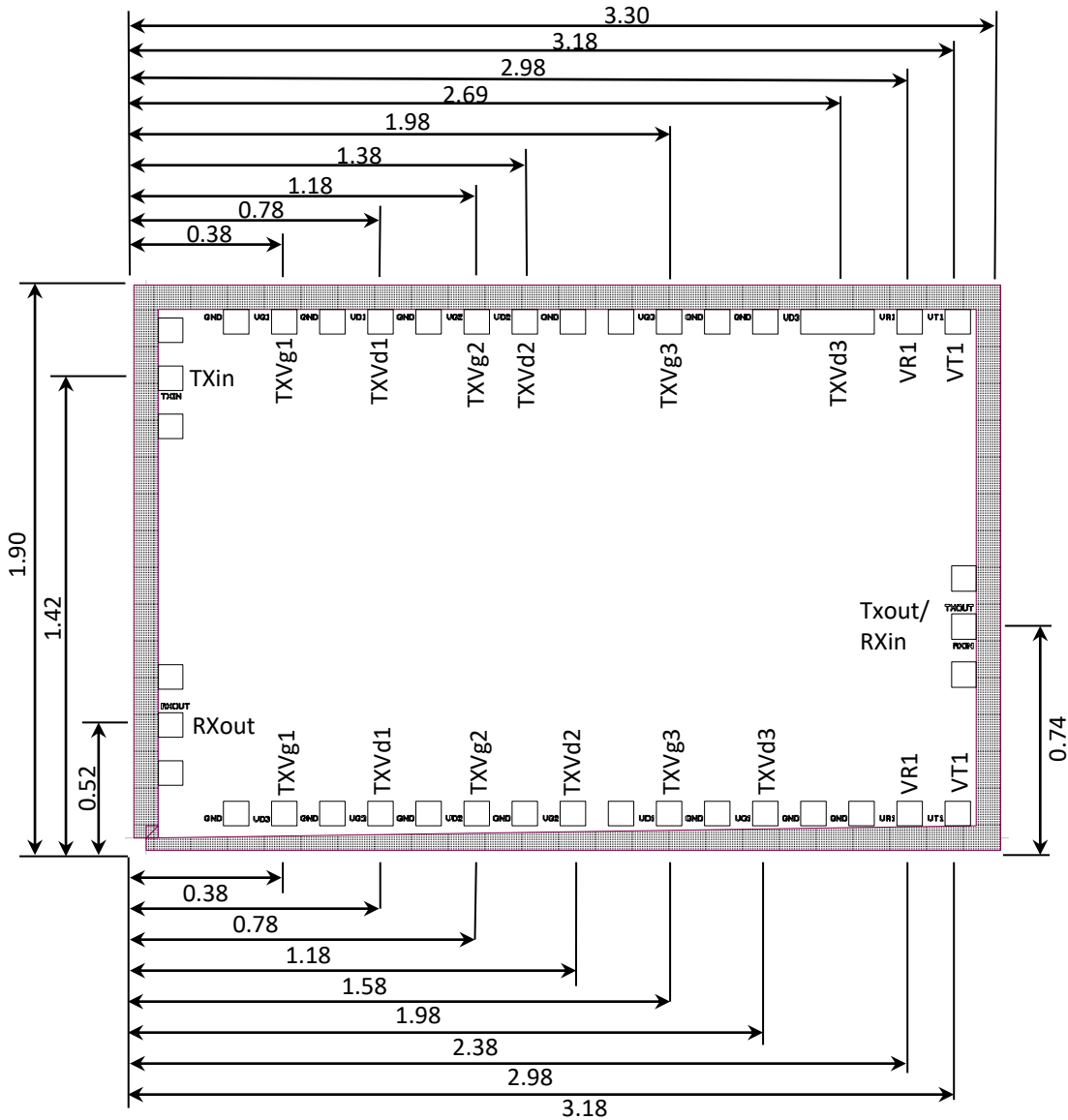

Important Information:

Nxbeam Inc. reserves the right to update and change without notice the characteristic data and other specifications as they apply to this document. Customers should obtain and verify the most recent product information before placing orders. Nxbeam Inc. assumes no responsibility or liability whatsoever for the use of the information contained herein.

The product represented by this datasheet is subject to U.S. Export Law as contained in ITAR or the EAR regulations.

ESD Sensitive Product

